

USER MANUAL

WhisperPower Battery Monitor

WBM Modular Smart Shunt



Table of Contents

1. INTRODUCTION	5
1.1 General	5
1.2 Box contents	5
1.3 Why a battery should be monitored	6
1.4 WBM Modular Smart Shunt highlights	6
1.5 CDU display and control overview	7
1.6 Active shunt status indicator	8
2. Quickstart	9
2.1 General	9
2.2 Setup wizard	9
3. NORMAL OPERATING MODE	11
3.1 Overview of parameter readouts	11
3.2 Display messages	14
3.3 Synchronization	14
4. STATUS MENU	15
5. HISTORY MENU	17
6. FUNCTION SETUP MENU	18
6.1 Battery bank 1 (Main) properties	18
6.2 Battery bank 2 properties	20
6.3 Battery bank 3 properties	21
6.4 System properties	21
6.5 Alarm properties	22
6.6 Display properties	24
6.7 Global properties	25
6.8 Advanced properties	25
7. RESET MENU	27
8. LOCK MENU	28
8.1 Locking the WBM Modular Smart Shunt	28
8.2 Unlocking the WBM Modular Smart Shunt	28
9. TROUBLESHOOTING GUIDELINE	29
10. TECHNICAL SPECIFICATIONS	30
11. WARRANTY CONDITIONS	31
12. DECLARATION OF CONFORMITY	32
13. INSTALLATION EXAMPLE	33

1. INTRODUCTION

1.1 General

Thank you for purchasing the WhisperPower Battery Monitor Modular Smart Shunt. Please read this owner's manual and the supplied installation guide for information about using the product correctly and safely. Keep this owner's manual and all other included documentation close to the product for future reference.

For the most recent manual revision and added content, please check the Downloads section on our website at <http://www.whisperpower.com/downloads>

The purpose of this owner's manual and the installation guide is to provide explanations and procedures for installing, configuring and operating the battery monitor. The installation instructions are intended for installers that should have knowledge and experience in installing electrical equipment, knowledge of the applicable installation codes, and awareness of the hazards involved in performing electrical work and how to reduce those hazards.

1.2 Box contents

The box should contain the following items:

- Active shunt module
- Display and Control Unit (CDU)
- Fused supply cable
- Shunt to CDU cable
- Bag with rubber port covers
- This owner's manual
- Installation guide

Please contact your supplier when any of these items show visual damage or when some items are missing.

1.3 Why a battery should be monitored

Operating your battery bank without good metering is like running your car without any gauges, although possible to do, it's always better to know how much fuel is left in the tank.

Defining the amount of energy available in a battery is a complex task, since battery age, discharge current and temperature all influence the actual battery capacity. The WBM Modular Smart Shunt is equipped with high performance measuring circuits and complex software algorithms, to exactly determine the remaining battery capacity.

Besides offering an accurate state of charge indication, the WBM Modular Smart Shunt will also help users how to get the best service life out of the battery bank. The service life of batteries will be negatively affected by excessive deep discharging, under- or overcharging, excessive charge- or discharge currents and/or high temperatures. The user can detect such abuse easily through the clear display of the WBM Modular Smart Shunt. Or alarms can be triggered when certain limits are exceeded, so that immediate measures can be taken. All this to extend the battery's lifetime and save costs in the long term.

1.4 WBM Modular Smart Shunt highlights

The WBM Modular Smart Shunt is our latest generation, highly advanced battery monitor. It consists of an intelligent active shunt and a remote control and display unit (CDU). The shunt has a Grid Optimized footprint for perfect integration with our DC Modular series of high current busbars and fuseholders.

This advanced battery monitor not only shows the true state of charge. It also offers a large amount of additional features to optimally supervise your battery system and control external equipment. The WBM Modular Smart Shunt is compatible with lead based and Lithium (LiFePO4) based batteries.

The WBM Modular Smart Shunt can monitor up to three battery banks. The inputs for battery bank 2 and 3 can also be configured for other purposes, like mid-point voltage measurement, key switch input or backlight control. The WBM Modular Smart Shunt battery monitor can measure DC currents up to 600Amps (500Amp continuous) and voltages up to 70Vdc. So any lead- or lithium based battery from 12V up to 48V can be monitored.

The installation time is minimal, requiring only one supply wire to the intelligent shunt base and a single plug and play 'QLINK' (QuickLink) cable between the active shunt and the CDU. Furthermore, the battery minus cable must be interrupted in order to insert the shunt into the high current circuit.

The WBM Modular Smart Shunt is equipped with two QLINK bus ports. In the simplest setup, only one of the QLINK ports will be used to connect to the CDU. However, additional accessories can be installed by employing the second QLINK port. Such accessories are for example communication interfaces or an alarm output expander box.

1.5 CDU display and control overview

Please see the image and information below for an overview of the display contents and the controls.

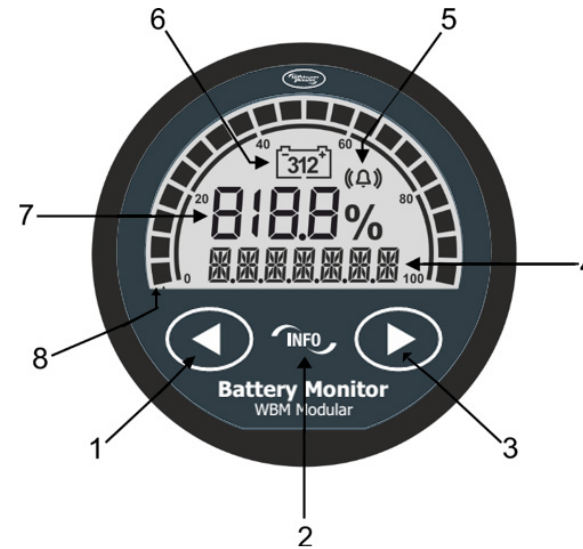

1. Left key (<) or Previous value
2. Menu or Enter key
3. Right key (>) or Next value
4. 7 character multipurpose information field
5. Alarm indicator
6. Selected battery input indicator
7. Value section for SoC (also for Function, Status and History parameter numbers)
8. State of Charge (SoC) bar. The five segment 0 – 100% grid will show an animation when there is a charge current (turning clockwise) or a discharge current (turning counter clockwise). The animation speed will also increase when the charge or discharge current increases.

1.6 Active shunt status indicator

The connection and installation details of the active shunt are already explained in the installation guide. However, the active shunt is also equipped with a smart status indicator light that deserves special attention. Please see the image below for the location of the status indicator:

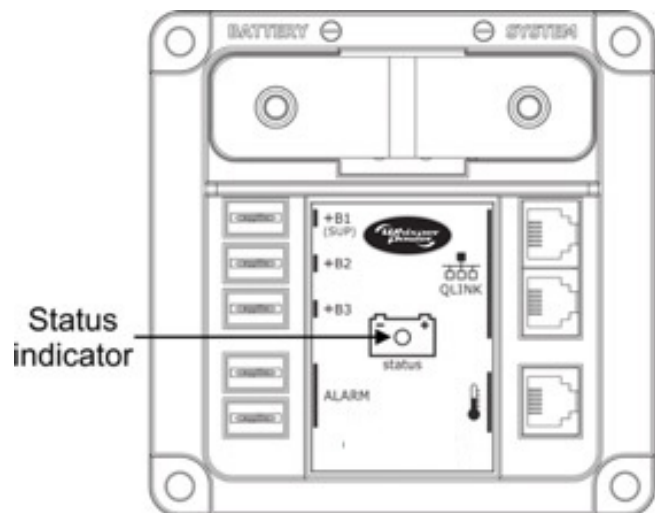

The status indicator has multiple operating modes, distinguished each by colour or flash interval. Please see the table below for an overview of the operating modes:

Table 1

Status colour	Status flash interval ¹⁾	Description
Green	Slow	Main battery healthy (SoC > 50%)
Orange	Slow	Main battery needs to be recharged (SoC = 30 – 50%)
Red	Slow	Main battery empty, recharge now (SoC < 30 %)
Red	Fast	Error
Orange	Fast	Initializing

¹⁾ Status flash interval times are 2 seconds for 'Slow' and 0.5 seconds for 'Fast'

2. QUICKSTART

2.1 General

This chapter describes the minimum amount of steps that need to be followed in order to get your Smart Shunt up and running. It assumes that the enclosed installation guide has been followed carefully and that the WBM Modular Smart Shunt is powered up for the first time. After this the Setup wizard will start automatically. If the Setup wizard does not start and The WBM Modular Smart Shunt will jump to the normal operating mode after power up, it has already been configured before. In that case you can choose to restore the factory default settings (see chapter 7, for more information) and start from the beginning. Please see the next chapter for more details about the Setup wizard.

2.2 Setup wizard

The Setup wizard will guide you through a few basic steps that are essential for a correctly functioning Smart Shunt. No other Function settings can be accessed before the Setup wizard has been completed.

Step 1-2: Main battery type

The display will start by showing the battery type selection screen. You can use the left (<) and right (>) arrow keys to select between AGM (default), GEL, Flooded and Lithium LiFePO4. Please consult your battery manual or supplier, to find out the correct type of your battery system. Once the selection has been made, press the MENU key to jump to the next step.



Step 2-2: Main battery capacity

The default battery capacity value is 200Ah. This can be changed by pressing the left or right arrow keys until the desired value is reached. The standard battery capacity value is based on a discharge rate of 20 hours. When your battery capacity is rated at a different discharge rate, please change this in Function F1.2 (see chapter 6.1) afterwards. Once the selection has been made, press the MENU key for 3 seconds to finalize the Setup wizard.





If you wish to make any changes to the Main battery type or capacity afterwards, you can always edit Functions F1.0 and F1.1 (see chapter 6.1).



The Setup wizard does not include any configuration steps for battery banks connected to the B2 and B3 inputs. If your system does include a second or third battery, please configure these manually using Functions F2 and F3 (see chapter 6.2 and 6.3).

After the Setup wizard has been completed, the WBM Modular Smart Shunt will take a few seconds to analyze your battery and estimate the nominal battery voltage as well as the current State of Charge (%). The State of Charge readout will show a small animation while it is calculating.



When a lithium battery type is selected, only the nominal battery voltage will be estimated. A start value for the State of Charge is not given yet and represented by '- - %'. A complete charge cycle is needed to obtain the exact State of Charge value.

For the highest accuracy, it is important that the battery is not being charged or discharged during this analysis time!

When your battery system has a nominal voltage level other than listed in table 2, you need to manually change this in Advanced Function A07.

Table 2 shows how the WBM Modular Smart Shunt determines the nominal voltage of your battery bank. This table is valid for all three battery bank inputs. Please note however, that inputs +B2 and +B3 do not support LiFePO4 batteries. As you can see in table 2, the estimated number of battery cells are also mentioned. Except for individual 2V lead- or 3V Lithium cells, all batteries contain a number of internal cells in series. A 12V lead acid battery for example, contains 6 cells internally. The WBM Modular Smart Shunt needs to know the number of cells, since its calculation algorithms are cell based.

Table 2

Measured voltage	Assumed nominal voltage for lead based battery (number of internal cells)	Assumed nominal voltage for LiFePO4 based battery (number of internal cells)
$V_{batt} < 5.0V$	-	-
$5.0 < V_{batt} < 7.5V$	6 V (3 cells)	6 V (2 cells)
$7.5 < V_{batt} < 10.0V$	6 V (3 cells)	9 V (3 cells)
$10.0 < V_{batt} < 15.0V$	12 V (6 cells)	12 V (4 cells)
$15.0 < V_{batt} < 20.0V$	18 V (9 cells)	18 V (6 cells)
$20.0 < V_{batt} < 30.0V$	24 V (12 cells)	24 V (8 cells)
$30.0 < V_{batt} < 40.0V$	36 V (18 cells)	36 V (12 cells)

Once the WBM Modular Smart Shunt shows the estimated state of charge value, it is now ready for use! Over time, it will keep on learning your battery and the estimated state of charge will become increasingly more accurate.

3. NORMAL OPERATING MODE

3.1 Overview of parameter readouts

In normal operating mode, the WBM Modular Smart Shunt can show you a wide range of important battery parameters. Each parameter can be accessed by pressing the left or right arrow keys. The main and most important parameter is the State of Charge (SoC) in %. This value will always be displayed and is also linked to the round bar graph at the outer edge of the display. Additionally, the WBM Modular Smart Shunt can show a second parameter at the bottom row of the display.

By default, the parameters voltage, current, time remaining and temperature are enabled with temperature only shown when an optional temperature sensor is connected. Additional parameters that are disabled by default are power and Amp-hours. The visibility of individual parameters can be enabled or disabled through functions F9.0 to F9.8.

The default settings will allow the second parameter to only show for 120 seconds after the WBM Modular Smart Shunt has been accessed. This will keep the display clean under normal conditions, which might be preferred by less technical end users. Function F9.9 sets the second parameter auto hide time and also offers an option to always show the second parameter (auto hide =OFF).

The table below shows all available parameter readouts:

Table 3

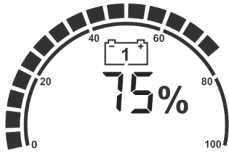
State of charge (SoC) (%)	
	<p>The SoC is the most important battery parameter. It shows exactly how much charge is left in the battery. This value is compensated for all known battery variables (age, charge/discharge current, temperature etc.). 100% represents a fully charged battery, while 0% represents a completely flat battery. Typically, you should recharge a lead based battery when the SoC has dropped below 50%. For a lithium based battery, this level can be lower.</p>

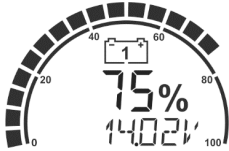
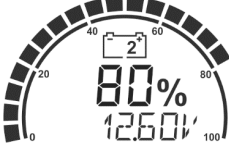
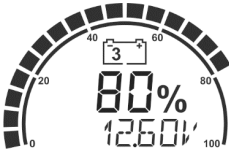
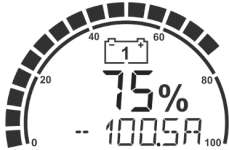
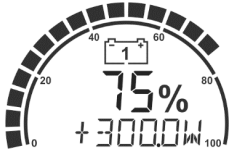
<p>Main battery voltage (V)</p> 	<p>Shows the voltage of the main battery bank connected to the +B1 input.</p>
<p>Battery bank 2 voltage (V)</p> 	<p>Shows the voltage of battery bank 2 (connected to the +B2 input). This value will only be shown when the +B2 input is configured as a second battery input (see Function F2.0).</p>
<p>Battery bank 3 voltage (V)</p> 	<p>Shows the voltage of battery bank 3 (connected to the +B3 input). This value will only be shown when the +B3 input is configured as a third battery input (see Function F3.0).</p>
<p>Main battery current (A)</p> 	<p>Shows the current flowing in- or out of the main battery. A negative sign indicates a discharge current and a positive sign a charge current.</p>
<p>Main battery power (W)</p> 	<p>Shows the power draw from the main battery (negative sign) or the power flow into the battery (positive sign). This reading is turned off by default and can be turned on in Function F9.2.</p>

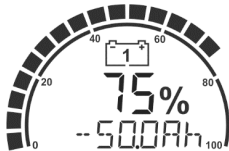
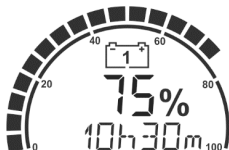
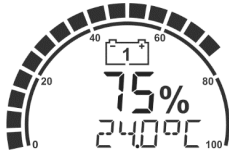
<p>Main battery Amp-hours (Ah)</p> 	<p>The amount of Amp-hours discharged from the battery. This reading is turned off by default and can be turned on in Function F9.3.</p>
<p>Main battery time remaining (h:m)</p> 	<p>Shows how much time is left under the present load, before the battery is empty.</p>
<p>Temperature (°C)</p> 	<p>Shows the battery temperature when a temperature sensor is connected to the WBM Modular Smart Shunt. The default temperature unit is °C, but it can be set to °F as well in Function F10.3.</p>

3.2 Display messages

The WBM Modular Smart Shunt can show a number of different status messages on the display. These will vary from advisory- to error messages. Please see the table below for the available messages

Table 4

Message	Explanation
'<battery name> Battery Full'	The main battery is fully charged. '<battery name>' will be replaced by the name given in Function 1.7
'Low Voltage'	Low battery voltage alarm ¹⁾
'High Voltage'	High battery voltage alarm ¹⁾
'Low Battery'	Low main battery State of Charge (SoC) alarm ¹⁾
'Low Time Remaining'	Low time remaining alarm for main battery ¹⁾
'High Charge Current'	High charge current alarm for main battery ¹⁾
'High Discharge Current'	High discharge current alarm for main battery ¹⁾
'Low Temperature'	Low temperature alarm for main battery ¹⁾
'High Temperature'	High temperature alarm for main battery ¹⁾
'High Midpoint Deviation'	High midpoint deviation alarm for main battery ¹⁾

¹⁾ The number inside the battery icon indicates to which battery the message applies

3.3 Synchronization

The WBM Modular Smart Shunt is a true next generation battery monitor that does not specifically require a full synchronization before you can actually use it (except for LiFePO4 batteries). The smart internal algorithms can already estimate the state of charge by performing a short battery analysis at start up. Unlike many other battery monitors on the market, the WBM Modular Smart Shunt will not get out of sync easily when the battery is not being fully charged (synchronized) very often.

Nevertheless, for the highest State of Charge (SoC) readout accuracy, it is still advisable to regularly synchronize the WBM Modular Smart Shunt with your battery. A synchronisation step means nothing more than performing a complete charge cycle on your battery. The WBM Modular Smart Shunt will automatically detect when a full charge cycle has been performed and resets the SoC value to 100%.

Performing full charge cycles regularly is also important to keep your battery healthy and to increase its lifetime.



Besides automatic synchronisations, you can also manually synchronize the battery monitor, when you are sure that your battery is fully charged. This can be accomplished by pressing both left and right arrow keys simultaneously for three seconds. After these three seconds, the SoC value will be reset to 100%.

For people who prefer to use the older auto synchronization method of the Expert Pro and Lite models, there is an Advanced function setting (A01) available that can be set to 'Legacy' mode. After it has been set to Legacy mode, all needed auto synchronization parameters will show up in the Advanced properties list to modify if desired. See chapter 6.8 for more information.

4. STATUS MENU

The Status menu is a read only menu that shows the current status of a number of Smart Shunt items. This menu can be accessed by the following sequence:

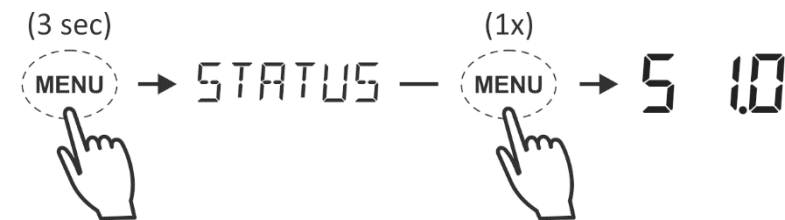

When the Status menu is entered, you can use the left and right arrow keys to browse through the different status items. By pressing the MENU key, the selected status item can be viewed. Pressing the MENU key again, will step back to the Status menu. From any menu position, the normal operating mode can be accessed again by pressing the MENU key for 3 seconds. The WBM Modular Smart Shunt will also jump back to the normal operating mode automatically after 30 seconds, when no keys are pressed during this time.

The following Status menu items are available:

Table 5

Status item	Status description
S 1.0	Name. Shows the name of this product.
S 1.1	Firmware version. Shows the firmware version of this product.
S 1.2	Hardware version. Shows the hardware version of this product.
S 1.3	Serial number. Shows the serial number of this product.
S 2.0	Alarm 1. Indicates if Alarm 1 is active.
S 2.1	Alarm 2. Indicates if Alarm 2 is active.
S 2.2	Alarm 3. Indicates if Alarm 3 is active.
S 2.3	Alarm 4. Indicates if Alarm 4 is active.
S 3.0	State of Health (SoH). Shows the SoH of your battery system.
S 3.1	Midpoint voltage. Shows the present midpoint voltage value.
S 3.2	Midpoint deviation. Shows the present midpoint deviation percentage
S 4.0	Total hours. Shows the number of hours that this product has been running.
S 4.1	Maintenance hours. Shows the number of hours left before maintenance is required.
S 4.3	Hours since charged. Shows the number of hours since the battery has last been charged.
S 4.4	Hours since synchronized. Shows the number of hours since the battery monitor has last been synchronized with the main battery.

5. HISTORY MENU

The History menu is a read only menu that shows the WBM Modular Smart Shunt's History data. History data are special events that are stored in internal memory. This menu can be accessed by the following sequence:

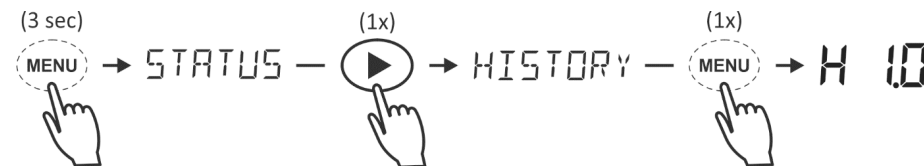

When the History menu is entered, you can use the left and right arrow keys to browse through the different History items. By pressing the MENU key, the selected History item can be viewed. Pressing the MENU key again, will then step back to the History menu. From any menu position, the Normal Operating Mode can be accessed again by pressing the MENU key for 3 seconds. The following History menu items are available:

Table 6

History item	History description
H 1.0	Average discharge (Ah). Average discharge of your main battery in Ah. This number will be recalculated after each synchronization.
H 1.1	Average discharge (%). Average discharge of your main battery in percent. This number will be recalculated after each synchronization.
H 1.2	Deepest discharge (Ah). Deepest discharge of your main battery in Ah.
H 1.3	Deepest discharge (%). Deepest discharge of your main battery in %.
H 1.4	Total Ah removed. The total number of Amphours removed from the main battery. When exceeding 999Ah, the units change to kAh and the displayed value must be multiplied by 1000.
H 1.5	Total Ah charged. The total number of Amphours charged to the main battery. When exceeding 999Ah, the units change to kAh and the displayed value must be multiplied by 1000.
H 1.6	Total kWh removed. The total number of kWh removed from the main battery. When exceeding 999kWh, the units are changed to MWh.
H 1.7	Total kWh charged. The total number of kWh charged to the main battery. When exceeding 999kWh, the units are changed to MWh.
H 1.8	Cycle count. The number of charge / discharge cycles.
H 1.9	Synchronization count. The number of synchronizations.
H 2.0	Alarm 1 count. The number of times Alarm 1 has been triggered.
H 2.1	Alarm 2 count. The number of times Alarm 2 has been triggered.
H 2.2	Alarm 3 count. The number of times Alarm 3 has been triggered.
H 2.3	Alarm 4 count. The number of times Alarm 4 has been triggered.

6. FUNCTION SETUP MENU

In the Function setup menu, your Smart Shunt can be adjusted further to fit your needs. This menu can only be entered after you have finished the initial Setup wizard. The following sequence gives access to the Function menu:

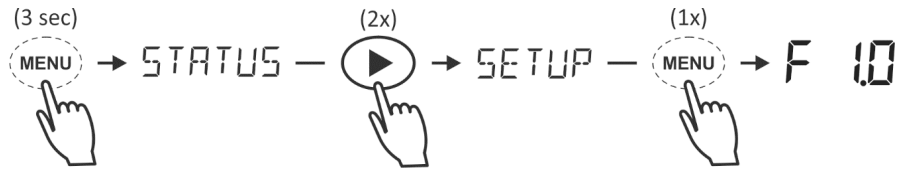

When the Function setup menu is entered, you can use the left and right arrow keys to browse through the different Functions. By pressing the MENU key, the selected Function value can be viewed. The left and right arrow keys can now be used to change this value. Pressing the MENU key again, will then step back to the Function menu. From any menu position, the normal operating mode can be accessed again by pressing the MENU key for 3 seconds. This will also save any Function value changes to internal memory. When no keys are pressed for 120 seconds while operating in the Function setup menu, the WBM Modular Smart Shunt will automatically return to the normal operating mode again without saving any Function value changes. All available Functions are described in the next chapters.



When the message 'Locked' appears on the display while trying to edit one of the Functions, the WBM Modular Smart Shunt should be unlocked first. See chapter 8 for more information.

6.1 Battery bank 1 (Main) properties

F1.0	Battery type. Choose the chemistry type of your battery. Table 7 shows the available types.		
	Default: AGM	Range: see table 7	

Table 7

Battery type	Description
AGM	Typical deep cycle sealed lead acid battery with Absorbed Glass Matt construction.
GEL	Typical deep cycle sealed lead acid battery with 'gelled' electrolyte.
Flooded	Typical flooded (wet-) lead acid battery.
LiFePO4	Typical Lithium iron Phosphate battery (does not apply to +B2 and +B3 inputs)

F1.1	Battery capacity. Your Main battery's capacity in Amphours (Ah).		
	Default: 200Ah	Range: 10 – 10000Ah	Step size: variable

F1.2	Nominal discharge rate (C-rating). The discharge rate (in hours) at which the battery manufacturer rates your battery's capacity.		
	Default: 20h	Range: 1 – 20h	Step size: 1h
F1.3	Nominal temperature. The temperature at which the battery manufacturer rates your battery's capacity.		
	Default: 20°C	Range: 0 – 40°C	Step size: 1°C
F1.4	Peukert's exponent. Peukert's exponent represents the effect of reducing battery capacity at higher discharge rates. When the Peukert value of your battery is unknown, it is recommended to keep this value at 1.17. A value of 1.00 disables the Peukert compensation and could be used for Lithium based batteries.		
	Default: 1.17	Range: 1.00 – 1.50	Step size: 0.01
F1.6	Battery temperature. In this Function the average battery temperature can be adjusted when no temperature sensor is connected. When a temperature sensor is connected, the temperature readout in the Normal Operating Mode is enabled.		
	Default: 20°C	Range: -20°C – 50°C	Step size: 1°C
F1.7	Battery bank 1 name. Choose a display name for your battery bank that comes nearest to your application.		
	Default: MAIN	Range: see table 8	

Table 8

Battery bank name	Description
Bank 1	Battery bank 1
Bank 2	Battery bank 2
Bank 3	Battery bank 3
Main	Main battery bank
Aux.	Auxiliary battery bank
Aux.1	Auxiliary battery bank 1
Aux.2	Auxiliary battery bank 2
Primary	Primary battery bank
Secndry	Secondary battery bank
Start	Starter battery
Service	Service battery bank
Accesry	Accessory battery bank
House	House battery bank
Port	Port battery
Starboard	Starboard battery bank

Power	Power battery bank
Gen.Strt	Generator starter battery
Bowtrst	Bow thruster battery
Radio	Radio battery
Vehicle	Vehicle battery
Trailer	Trailer battery
Drive	Drivetrain battery
Brake	Brake battery
Solar	Solar battery
Other	Other battery

6.2 Battery bank 2 properties

F2.0	Battery bank 2 function. Set the function for the battery bank 2 (+B2) input.		
	Default: DISABLE	Range: see table 9	

Table 9

Function	Description
DISABLE	Input is not used.
AUX.BAT	Use input for monitoring an additional battery bank.
MAIN.BAT	Use input for measuring the voltage of the Main battery bank. This can be useful for systems with a long supply wire to the +B1 input. In order to avoid measurement errors due to voltage drops across the combined supply/sense wire, the voltage can also be measured independently via +B2 or +B3.
MIDPNT	Use input for midpoint or center voltage measurement in 24V and 48V systems. For more information on midpoint voltage measurement and setup, please see appendix 1 in the online version of this manual, available at www.whisperpower.com/downloads
KEYSW.	Use input to connect to an external key switch to turn off the CDU display. This can be used to mimic a turned off battery monitor when it is installed in the dashboard of an EV. The CDU display will still temporarily turn on when a button is pressed on the front panel. The active shunt keeps on operating in the back-ground. A voltage < 1V turns off the display and a voltage of > 1.5V turns it on.
HOURENT	Use input to control hour counting (Total- and Maintenance hours). When the applied voltage is >1.5V, hour counting will start. When the voltage is < 1V, hour counting will be paused again. This option can be used to accumulate the operating hours of the complete system, such as a forklift truck.
BKLIGHT	Use input to enable or disable the display backlight of the CDU. When the applied voltage is > 1.5V, the backlight is enabled. When the voltage is < 1V, the backlight is disabled.

F2.1	Battery bank 2 type (will only show when F2.0 is set to AUX.BAT). Choose the chemistry type of your battery.		
	Default: AGM	Range: see table 7	
F2.2	Battery bank 2 name (will only show when F2.0 is set to AUX.BAT). Choose a display name for your battery bank that comes nearest to your application.		
	Default: AUX.1	Range: see table 8	

6.3 Battery bank 3 properties

F3.0	Battery bank 3 function. Set the function for the battery bank 3 (+B3) input.		
	Default: DISABLE	Range: see table 9	
F3.1	Battery bank 3 type (will only show when F3.0 is set to AUX.BAT). Choose the chemistry type of your battery.		
	Default: AGM	Range: see table 7	
F3.2	Battery bank 3 name (will only show when F3.0 is set to AUX.BAT). Choose a display name for your battery bank that comes nearest to your application.		
	Default: AUX.2	Range: see table 8	

6.4 System properties

F4.0	Time remaining averaging filter. Specifies the time window of the moving averaging filter. There are four settings, where setting 0 gives the fastest Time remaining readout response and setting 3 the slowest. The best setting will depend on the type of battery load and your personal preference.		
	Default: 1	Range: 0 – 3	Step size: 1
F4.1	Enable maintenance hour count. When set to OFF, only the operating hours are accumulated which starts once the battery monitor is being powered up (unless Functions F2.0 or F3.0 are set to HOURENT, so that operating hours are only counted when the +B2 or +B3 input is 'high'). When set to ON, the counted hours are being subtracted from the Maintenance interval hours set in Function F4.2.		
	Default: OFF	Range: OFF / ON	
F4.2	Maintenance interval. Choose a time schedule for maintenance. When Function F4.1 is set to ON, the accumulated operating hours are being subtracted from the maintenance interval hours set in this Function. A maintenance alarm message will automatically appear on the display, once the maintenance interval has reached 0 hours.		
	Default: 5000h	Range: 100 – 100000h	Step size: 100h

6.5 Alarm properties

The WBM Modular Smart Shunt offers four independent configurable alarms. This offers great flexibility for the installer. Whether you wish to configure four completely different alarm types, or trigger an individual alarm on for example four different State of Charge values, there are almost limitless possibilities. Especially when adding an optional Alarm Output Expander to your Smart Shunt system. This will allow each alarm to trigger a dedicated alarm relay.

F5.0	Alarm 1 type. Choose which parameter will trigger this alarm. The default 'SOC.Low' will trigger an alarm when the State of Charge has dropped below a bottom limit. All available alarm types are described in table 10.		
	Default: SOC.Low	Range: see table 10	

Table 10

Alarm type	On value (default)	Off value (default)	Range	Alarm description
OFF	-	-	-	Alarm not used
V.LOW (bank1)	10.5V	11.0V	7.0V - 70.0V	Low battery voltage. When the voltage falls below the On value, the associated alarm will be activated. When the voltage rises above the Off value, this alarms will be deactivated again.
V.HIGH (bank1)	16.0V	15.5V		High battery voltage. When the voltage rises above the On value, the associated alarm will be activated. When the voltage falls below the Off value, this alarm will be deactivated again.
SOC.LOW (bank1)	40%	80%	0% - 99%	Low State of Charge. When the SoC falls below the On value, the associated alarm will be activated. When the SoC rises above the Off value, this alarm will be deactivated again.
TIME.LOW (bank1)	0h30m	1h00m	1min – 24hrs	Low time remaining. When the time remaining falls below the On value, the associated alarm will be activated. When the time remaining rises above the Off value, this alarm will be deactivated again.
I.CHARGE (bank1)	10.0A	9.0A	1.0A - 600.0A	High charge current. When the charge current exceeds the On value, the associated alarm will be activated. When the charge current falls below the Off value, this alarm will be deactivated again.
I.DISCH (bank1)	10.0A	9.0A		High discharge current. When the discharge current exceeds the On value, the associated alarm will be activated. When the charge current falls below the Off value, this alarm will be deactivated again.
T.LOW (bank1)	0°C	1°C	-20°C .. +50°C	Low battery temperature. When the temperature falls below the On value, the associated alarm will be activated. When the temperature rises above the Off value, this alarm will be deactivated again.

T.HIGH (bank1)	40°C	39°C	-20°C .. +50°C	High battery temperature. When the temperature exceeds the On value, the associated alarm will be activated. When the temperature falls below the Off value, this alarm will be deactivated again.
MIDPNT (bank1)	2.0%	0.5%	0.0% - 50.0%	Midpoint voltage deviation. When the deviation exceeds the On value, the associated alarm will be activated. When the deviation falls below the Off value, this alarm will be deactivated again. For more information on midpoint voltage measurement and setup, please see appendix 1 in the online version of this manual, available at www.whisperpower.com/downloads
V.LOW (bank2)	10.5V	11.0V	7.0V - 70.0V	Low battery voltage. When the voltage falls below the On value, the associated alarm will be activated. When the voltage rises above the Off value, this alarm will be deactivated again.
V.HIGH (bank2)	16.0V	15.5V		High battery voltage. When the voltage rises above the On value, the associated alarm will be activated. When the voltage falls below the Off value, this alarm will be deactivated again.
V.LOW (bank3)	10.5V	11.0V	7.0V - 70.0V	Low battery voltage. When the voltage falls below the On value, the associated alarm will be activated. When the voltage rises above the Off value, this alarm will be deactivated again.
V.HIGH (bank3)	16.0V	15.5V		High battery voltage. When the voltage rises above the On value, the associated alarm will be activated. When the voltage falls below the Off value, this alarm will be deactivated again.

F5.1	Alarm 1 on value. Activates the alarm when the parameter has reached this value.		
	Default: see table 10	Range: see table 10	Step size: variable
F5.2	Alarm 1 off value. Deactivates the alarm when the parameter has reached this value.		
	Default: see table 10	Range: see table 10	Step size: variable
F5.3	Alarm 1 on delay. This is the time the alarm on condition of F5.1 must be met before the alarm is activated.		
	Default: 10sec	Range: 0 – 3600sec	Step size: variable
F5.4	Alarm 1 off delay. This is the time the alarm off condition of F5.2 must be met before the alarm is deactivated.		
	Default: 0sec	Range: 0 – 3600sec	Step size: variable

F5.5	Warning. Choose whether or not the active alarm is shown on the display ('VIS.') or an audible alarm ('AUD') will sound. The audible alarm will stop sounding when the alarm has been cleared, or when a key is pressed. When the audible alarm is not interrupted, the alarm interval will slow down automatically against time.	
	Default: VIS.+AUD	Range: OFF / VIS. / VIS.+AUD
F5.7	Alarm contact. Choose which alarm relay contact to use with this alarm. Select "OFF" to not use any alarm contact. Select "INT." to use the battery monitor's internal alarm relay. Select "EXT.1" to "EXT.8" to use an external alarm contact (only for use with the optional relay accessories).	
	Default: INT.	Range: OFF / INT. / EXT.1 – EXT.8

The Alarms 2, 3 and 4 can be configured in respectively Functions F6.0 - F6.7, F7.0 – F7.7 and F8.0 – F8.7. Each Function range contains the same settings options as for Alarm 1 (F5.0 – F5.7).

6.6 Display properties

These Functions can be used to personalize the normal operating mode. You can choose to skip viewing parameters in the bottom display row that you are not interested in. The State of Charge value shown in the upper parameter row cannot be skipped.

F9.0	Show voltage.	
	Default: ON	Range: OFF / ON
F9.1	Show current.	
	Default: ON	Range: OFF / ON
F9.2	Show power.	
	Default: OFF	Range: OFF / ON
F9.3	Show Amp-hours.	
	Default: OFF	Range: OFF / ON
F9.4	Show time remaining.	
	Default: ON	Range: OFF / ON
F9.5	Show temperature.	
	Default: ON	Range: OFF / ON
F9.7	Show bank 2 voltage. Only available when F2.0 is set to AUX.BAT.	
	Default: ON	Range: OFF / ON

F9.8	Show bank 3 voltage. Only available when F3.0 is set to AUX.BAT.	
	Default: ON	Range: OFF / ON
F9.9	Auto hide parameter. The default setting will allow the bottom parameter to only show for 120 seconds after the WBM Modular Smart Shunt has been accessed. This will keep the display clean under normal conditions, which might be preferred by less technical end users. When auto hide is set to OFF, the bottom parameter row is always visible.	
	Default: 120sec	Range: OFF / 5 – 300sec

6.7 Global properties

F10.0	Backlight timer. Represents the duration of backlight activation in seconds after key-press. The backlight can also be set to be always "ON" or always "OFF".		
	Default: 30sec	Range: OFF / 5 – 300sec / ON	Step size: variable
F10.1	Backlight auto on. When set to "ON", The backlight is automatically activated when the charge / discharge current exceeds 1Amp.		
	Default: OFF	Range: OFF / ON	
F10.2	Alarm contact polarity. Enables selection between a normally open (NO) or normally closed (NC) contact.		
	Default: N/O	Range: N/O – N/C	
F10.3	Temperature units. Enables selection between degrees Celsius (°C) and degrees Fahrenheit (°F) in the temperature readout.		
	Default: °C	Range: °C / °F	

6.8 Advanced properties

A01	Auto-sync mode. Choose which mode to use to automatically synchronize the WBM Modular Smart Shunt with your battery when it is fully charged. The default mode is STANDRD which is the preferred setting for most applications. The setting LEGACY represents an auto-sync mode as used in the Expert Pro and Lite battery monitors. This mode can be selected when the installer wishes to have more control over the auto-sync conditions. These conditions can be set in Functions A02, A03, A04 and A05 once A01 is set to LEGACY. Only when the conditions of A02 and A03 are both met during the time period set in A04, the battery is considered fully charged and the SoC value is set to 100%.	
	Default: STANDRD	Range: STANDRD / LEGACY

A02	Auto-sync voltage (will only show when A01 is set to LEGACY). The battery voltage must be above this level to consider the battery as fully charged. This value must be slightly below your battery charger's float voltage (0.1 – 0.3V), which is the last stage of the charging process. The default value can be multiplied by 2 or 4 if respectively 24V or 48V systems are connected to the WBM Modular Smart Shunt.		
	Default: 13.2V	Range: 7.0 – 70.0V	Step size: 0.1V
A03	Auto-sync current (will only show when A01 is set to LEGACY). When the charge current is below this percentage of the battery capacity (see Function F1.1), the battery will be considered as fully charged. Make sure that this value is always slightly greater than the current at which the charger maintains the battery or stops charging.		
	Default: 2.0%	Range: 0.5 - 10.0%	Step size: 0.1%
A04	Auto-sync time (will only show when A01 is set to LEGACY). This is the time that both Auto-sync parameters A02 and A03 must be met in order to consider the battery as fully charged.		
	Default: 240sec	Range: 0 – 3600sec	Step size: variable
A05	Auto-sync sensitivity (will only show when A01 is set to LEGACY). Only change this setting when A02, A03 and A04 are set correctly and automatic synchronization still fails. If automatic synchronization takes too long or does never occur, lower this value. When the battery monitor synchronizes too early, increase this value.		
	Default: 5	Range: 0 – 10	Step size: 1
A07	Bank 1 series cell count. Allows you to edit the number of internal series cells of your used batteries that was automatically determined after completing the Setup Wizard. See table 2 in chapter 2.2 for more information.		
	Default: dynamic	Range: 2 – 30	Step size: 1
A08	Bank 2 series cell count (will only show when F2.0 is set to AUX.BAT). Allows you to edit the number of internal cells of your used batteries, that was automatically determined after completing the Setup Wizard. See table 2 in chapter 2.2 for more information.		
	Default: dynamic	Range: 2 – 30	Step size: 1
A09	Bank 3 series cell count (will only show when F3.0 is set to AUX.BAT). Allows you to edit the number of internal cells of your used batteries, that was automatically determined after completing the Setup Wizard. See table 2 in chapter 2.2 for more information.		
	Default: dynamic	Range: 2 – 30	Step size: 1
A12	Temperature averaging filter. Specifies the noise filter setting at the temperature sensor input. The default value of 1 will be fine for most applications. Only in case of long temperature sensor cables and/or environments with extremely high RF interference levels, it is advised to set this value to 2.		
	Default: 1	Range: 0 – 2	Step size: 1



All changed Function settings remain in the WBM Modular Smart Shunt's internal memory. Even when the supply voltage has been interrupted. This also applies to the stored Status and History items.

7. RESET MENU

In the Reset menu, you can reset a number of battery monitor items. This menu can be accessed by the following sequence:

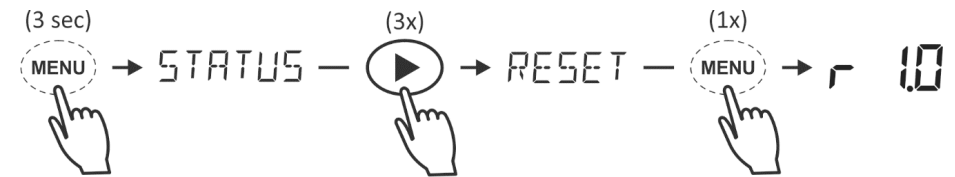

When the Reset menu is entered, you can use the left and right keys to browse through the different reset items. By pressing the MENU key, the selected reset item can be viewed. The default value for all reset items is NO. To actually reset the selected item, use the left and right keys to change the value from NO to YES or vice versa. Pressing the MENU key again, will step back to the Reset menu. All reset items set to YES will only be reset once the Normal Operating Mode is accessed again by pressing the MENU key for 3 seconds. The following Reset menu items are available:

Table 11

Reset item	Reset description
r 1.0	Reset Alarms. Use this item to suppress all present alarms. Associated alarm contacts will be turned off and the alarm indicator on the display will also be turned off. A suppressed alarm can only be re-triggered when the alarm's off conditions are met first.
r 1.1	Reset Maintenance Hours. Resets the maintenance hour counter (status item S4.1). This reset item is only of importance when maintenance hours are enabled (function F4.1 is set to ON). Use this reset item when a maintenance job has been performed.
r 1.2	Reset Battery. Use this item to reset your current battery status and history information. This can be applied after you have installed a fresh battery of the same specifications as the previous one.
r 1.3	Factory Reset. This reset item can be used to reset all Function, Status and History values to factory default values. After a factory reset, the WBM Modular Smart Shunt restart to the Setup Wizard again.

8. LOCK MENU

In the Lock menu, you can lock or unlock the Function setup and Reset¹⁾ menu of the WBM Modular Smart Shunt by entering a pin code. Locking these menus can be useful to prevent untrained personnel for making any changes to the instrument's settings. This menu can be accessed by the following sequence:

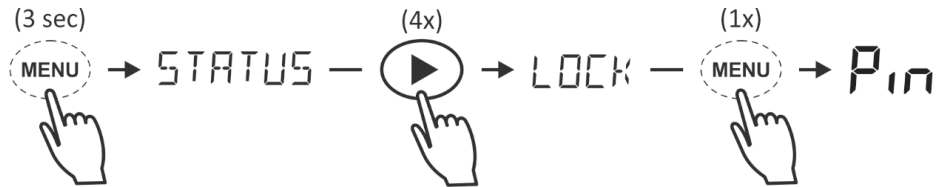

¹⁾ In the Reset menu, only Reset Alarms (r1.0) will remain available when the unit is locked

8.1 Locking the WBM Modular Smart Shunt

When the Lock menu is entered, the following flashing input field will be displayed:

□ _ _ _

Your desired pin code can now be entered by using the left and right keys to change the number (0..9) for each of the four digits. By pressing the MENU key, you can jump to the next digit. When the fourth digit has been entered, pressing the MENU key will store the pin code and the display will shortly show 'LOCK OK' before jumping back to the normal operating mode. Now the Setup and Reset menus are read only, blocking any attempt to change a setting. When no pin code is entered for 15 seconds, the WBM Modular Smart Shunt will automatically jump back to the main menu again.

8.2 Unlocking the WBM Modular Smart Shunt

When you wish to unlock the WBM Modular Smart Shunt, you will notice that menu name 'LOCK' has been changed to 'UNLOCK'. This is an indication that the unit is currently locked. Using the same method as explained in chapter 8.1, you can access the unlock menu and start entering the previously determined pin code. When the correct pin code has been entered, the display will shortly show 'PIN OK' before jumping back to the normal operating mode. Now you can make changes again in the Setup and Reset menus. When an incorrect pin code has been entered, the display will shortly show 'FALSE' before jumping back to the flashing input field again. After three false attempts, the unit jumps back to the normal operating mode.

9. TROUBLESHOOTING GUIDELINE

Problem	Remedy or suggestion
The monitor doesn't operate (no LED on the shunt or no display on the CDU)	<ul style="list-style-type: none"> • Check shunt- and battery side connections • Check QLink cable to the CDU • Make sure the inline fuse of the supply wire is installed and not blown • Check battery voltage (must be > 6.5V) • Try to restart the monitor by removing and reconnecting the supply wire
Current readout gives wrong polarity (current should positive when charging and negative when discharging the battery)	<ul style="list-style-type: none"> • Shunt installed in reverse. Make sure that the 'Battery -' bolt is connected to the battery negative terminal and the 'System -' bolt to the battery loads.
No changes can be made in the Function setup menu (the text 'Locked' appears when trying to change a value)	<ul style="list-style-type: none"> • The battery monitor is locked by the installer. Please see chapter 8 for more details.
State of Charge or Time remaining readout not accurate	<ul style="list-style-type: none"> • Check if all current is flowing through the shunt (the negative terminal of the battery may only contain the wire going to the 'battery -' side of the shunt!) • Shunt installed in reverse. Make sure that the 'Battery -' bolt is connected to the battery negative terminal and the 'System -' bolt to the battery loads. • Check if all battery properties (F1.x) are correctly set • Check if the battery monitor is synced with your battery. Perform full charge cycle.
Display returns '- .-' in temperature readout	<ul style="list-style-type: none"> • Connection with the temperature sensor is lost. Check sensor cable.
The monitor resets all the time	<ul style="list-style-type: none"> • Check wiring for corrosion or bad contacts • Battery might be flat or defective
The monitor does not automatically synchronize	<ul style="list-style-type: none"> • The battery is not reaching its fully charged state. Please check if the charge algorithm matches the requirements of your battery. Do not interrupt the charge process before it is finished. • Consider setting Advanced Function A01 to 'LEGACY' and tweak Functions A02 – A05 to better match it to your system.
The monitor synchronizes too early	<ul style="list-style-type: none"> • In some systems (like solar) the charge current can fluctuate heavily, causing the battery monitor to consider the battery fully charged too early. In this case, Function A01 can be set to 'LEGACY' and Function A02 approx. 0.2V-0.3V below the absorption voltage.

10. TECHNICAL SPECIFICATIONS

Parameter	Smart Shunt
Supply voltage range	7..70Vdc
Supply current (@ 12V/ 24V/48V)	10mA / 6mA / 5mA
Input voltage range main battery (+B1)	7..70Vdc ¹⁾
Input voltage range second and third battery (+B2, +B3)	1..70Vdc
Input current range	-600..+600A ²⁾
Battery capacity range	10..10000Ah
Operating temperature range	-20..+50°C
Storage temperature range	-30..+70°C
Readout resolution: Voltage (0..70V) Current (0..10A) Current (10..100A) Current (100..600A) State of Charge (0..100%) Time remaining (0..24hrs) Time remaining (24..240hrs) Amphours (0..10000Ah) Power (0..42kW) Temperature (-20°C..+50°C)	± 0.01V ± 0.01A ± 0.1A ± 1A ± 1% ± 1min ± 1hr ± 0.01Ah..10Ah (variable) ± 0.01W..1kW (variable) ± 0.5°C
Voltage measurement accuracy	± 0.3%
Current measurement accuracy	± 0.4%
Shunt dimensions: Footprint Base height Total height Weight	100 x 100mm 24.0mm 64.5mm 290grams
Display dimensions: Front panel Body diameter Total depth Weight	Ø 64.0mm Ø 51.5mm 36.0mm 70grams
Protection class	IP20 (shunt vertically mounted) IP65 (CDU front panel only)
Standards	CE certified (EMC Directive 2014/30/EU) including EN50498 Automotive EMC

All specifications are subject to change without notice

¹⁾ When input +B1 is only used for supply and +B2 for main battery voltage measurement, the input voltage range for the main battery is 1..70Vdc.

²⁾ +/- 600A is the maximum rating for 20 minutes. The continuous input current range is +/- 500A.



Please act according to your local rules and do not dispose of your old products with the normal household waste. The correct disposal of your old product will help prevent potential negative consequences for the environment and human health.

11. WARRANTY CONDITIONS

WhisperPower warrants this product to be free from defects in workmanship or materials for 24 months from the date of purchase. During this period TBS will repair the defective product free of charge. TBS is not responsible for any transport costs of this product.

This warranty is void if the product has suffered any physical damage or alteration, either internally or externally, and does not cover damage arising from improper use¹⁾, or from use in an unsuitable environment.

This warranty will not apply where the product has been misused, neglected, improperly installed or repaired by anyone other than TBS. TBS is not responsible for any loss, damage or costs arising from improper use, use in an unsuitable environment, improper installing of the product and product malfunctioning.

Since TBS cannot control the use and installation (according to local regulations) of their products, the customer is always responsible for the actual use of these products. TBS products are not designed for use as critical components in life support devices or systems, which can potentially harm humans and/or the environment. The customer is always responsible when implementing TBS products in these applications. TBS does not accept any responsibility for any violation of patents or other rights of third parties, resulting from the use of the TBS product. TBS keeps the right to change product specifications without previous notice.

¹⁾ Examples of improper use are:

- Too high input voltage applied
- Wrong shunt installation
- Too high current through shunt
- Mechanically stressed enclosure, display or internals due to harsh handling or incorrect packaging
- Contact with any liquids or oxidation caused by condensation

12. DECLARATION OF CONFORMITY

MANUFACTURER : WhisperPower B.V.
 ADDRESS : Kelvinlaan 82
 9207 JB Drachten
 The Netherlands

Declares that the following product :

PRODUCT TYPE : Battery monitor
 MODEL : WBM Modular Smart Shunt

Conforms to the requirements of the following Directives of the European Union :

EMC Directive 2014/30/EU
 Low voltage Directive 2014/35/EU
 Automotive Directive 2004/108/EC
 RoHS Directive 2011/65/EU

The above product is in conformity with the following harmonized standards :

EMC: EN55016-2-1/(A1), EN55016-2-3/(A1), EN 61000-4-2(3/4/5/6), EN 50498
 Safety: EN60335-1:2012, EN60335-2-29:2004

13. INSTALLATION EXAMPLE

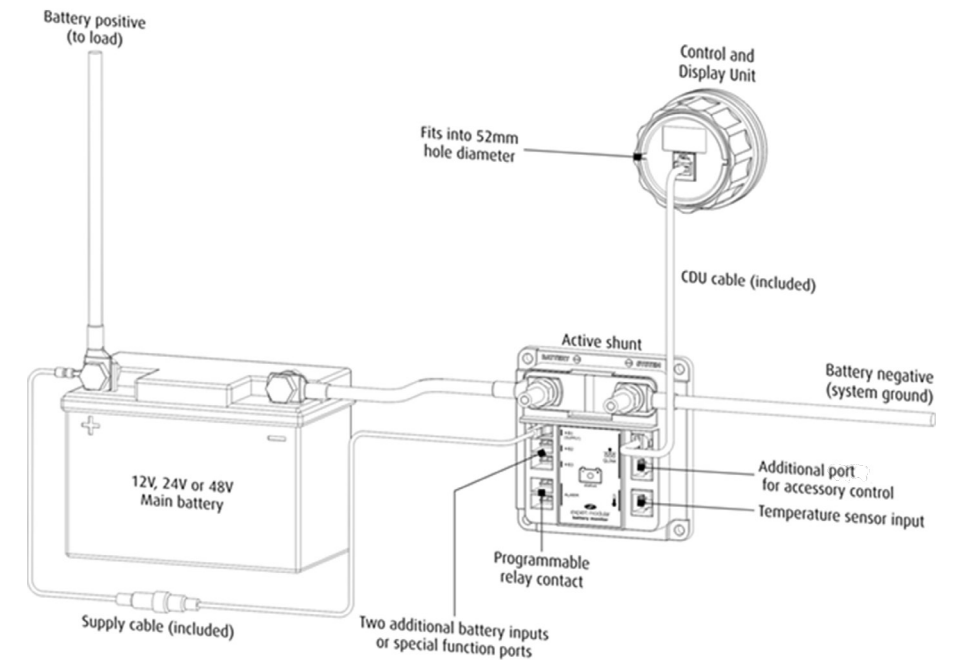



Generating Confidence

WhisperPower BV

Kelvinlaan 82,
9207 JB Drachten
The Netherlands

Tel: +31 (0) 512 571 550

Fax: +31 (0) 512 571 599

E-mail: sales@whisperpower.com

For more information go to www.whisperpower.com

